

# TORNADO

By Duraquip

## 2 COMPARTMENT SPECIFICATIONS

### GA DRAWING / HOPPER SPLITS

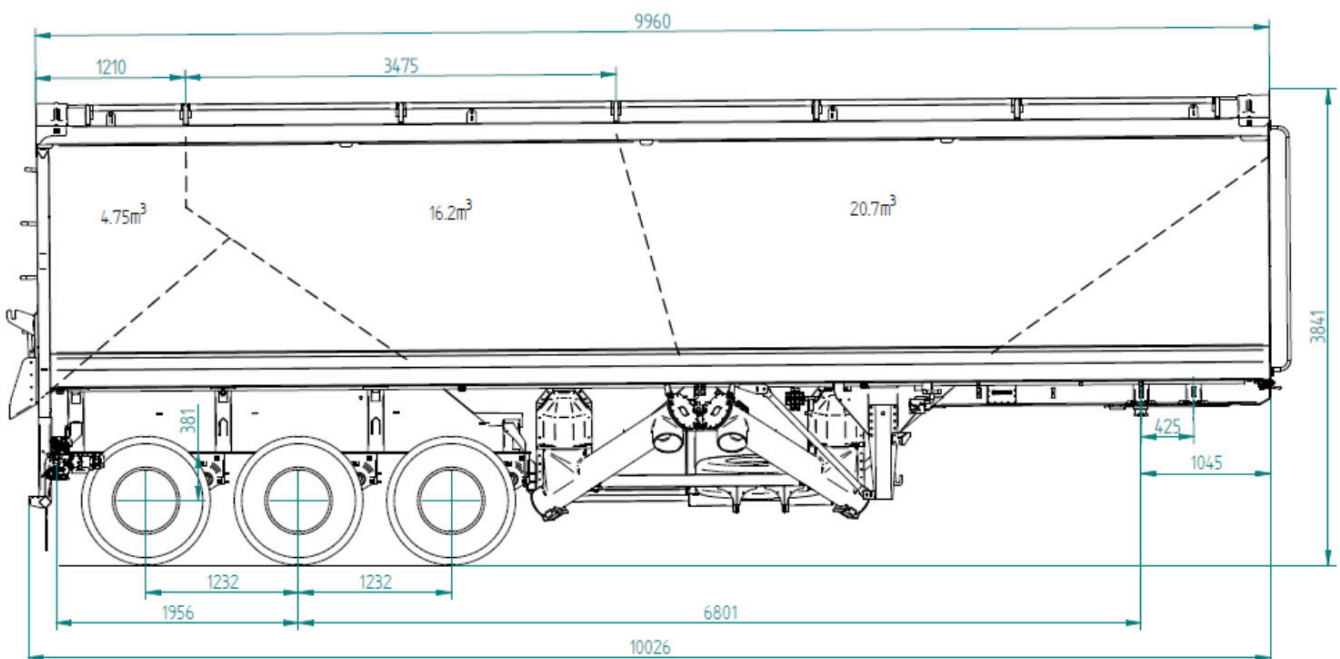

### HOPPER CAPACITIES

TOTAL	41.6M3	WHEAT	BARLEY	FERTILISER	UREA
HOPPER 1	20.7m3	16.56T	14.5T	20.7T	14.5T
HOPPER 2	16.2m3	13.36T	11.7T	16.7T	11.7T
REAR	4.7m3	3.76T	3.76T	4.7T	3.29T
TARE WEIGHT 8.4T					

### SUB-FRAME COLOURS



Call our knowledgeable sales team today to discuss the TORNADO and which model will best suit your operations!



1800 27 1800 | [sales@duraquip.com.au](mailto:sales@duraquip.com.au)